

# TM series

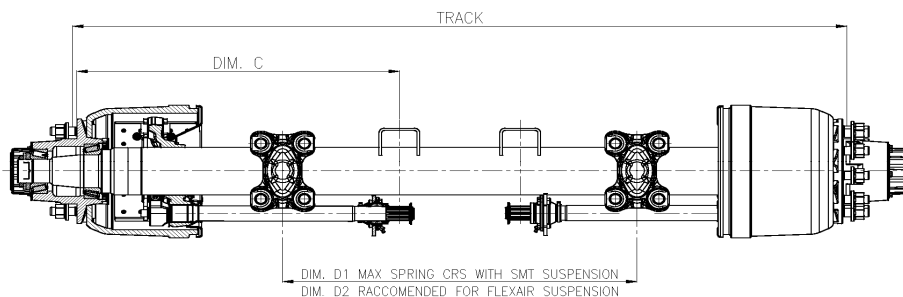

310X190 (AC) DRUM BRAKE						
Type	Track	Wheel	C	D1 max	D2 max	Cap. t
TMA#225	1820	single/twin	790	990	960	10
	1880	single/twin	790	1050	1020	10
	1920	single/twin	790	1090	1060	10
	1950	twin	790	1120	1090	10
	2000	single/twin	790	1170	1140	10
	2045	single/twin	790	1215	1185	10
	2100	single	790	1270	1240	10
2128	twin	790	1298	1268	10	
TMA#250	1820	single/twin	790	990	960	12
	1920	single/twin	790	1090	1060	12
	2000	twin	790	1170	1140	12
	2045	twin	790	1215	1185	12

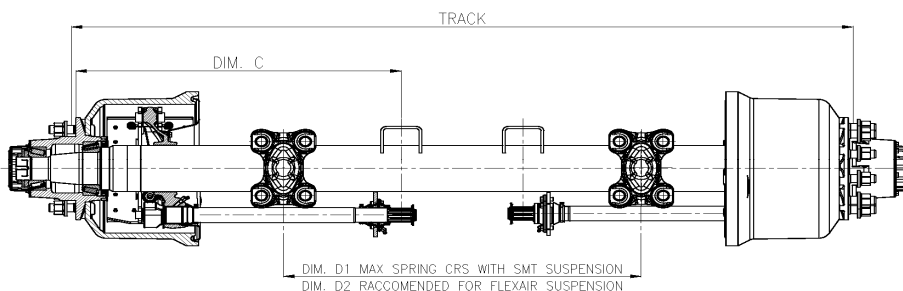

350x200 (B) DRUM BRAKE						
Type	Track	Wheel	C	D1 max	D2 max	Cap. t
TMB#225	1820	twin	778	990	960	10
	1850	twin	778	1030	1000	10
	1880	single/twin	778	1050	1020	10
	1920	twin	778	1090	1060	10
	2045	single	778	1215	1185	10
2128	single	778	1298	1268	10	
TMB#250	1850	twin	778	1030	1000	12
	1880	single/twin	778	1060	1030	12
	1920	twin	778	1100	1070	12
	1950	twin	778	1130	1100	12
	2128	twin	778	1300	1270	12

350x200 (B) DRUM BRAKE 84 offset hub						
Type	Track	Wheel	C	D1 max	D2 max	Cap. t
TMBO#225	1820	single	778	990	960	10

# TM series

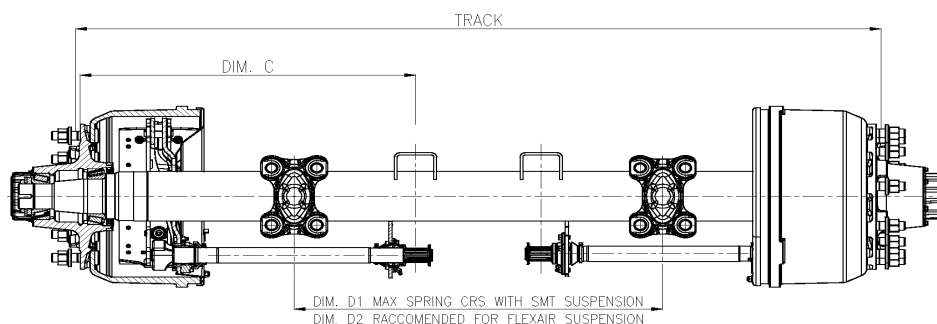

420X180 (Q) DRUM BRAKE						
Type	Track	Wheel	C	D1 max	D2 max	Cap. t
TMQ#225	1820	twin	760	1020	990	10
	1920	single	760	1120	1090	10
	1950	twin	760	1150	1120	10
	2045	single/twin	760	1250	1220	10
	2068	single	760	1300	1270	10
	2128	single	760	1328	1298	10
TMQ#250	2045	single	760	1250	1220	12

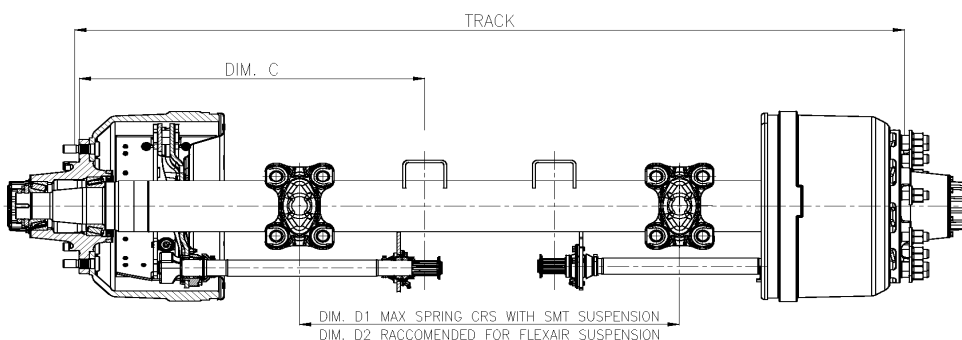

420X220 (Z) DRUM BRAKE						
Type	Track	Wheel	C	D1 max	D2 max	Cap. t
TMZ#225	1820	twin	760	1020	990	10
	1850	twin	760	1050	1020	10
	1880	twin	760	1080	1050	10
	1920	twin	760	1120	1090	10
	1950	twin	760	1150	1120	10
	2045	single/twin	760	1250	1220	10
TMZ#250	1820	twin	760	1020	990	12
	1850	twin	760	1050	1020	12
	1880	twin	760	1080	1050	12
	1920	twin	760	1120	1090	12
	1950	single/twin	760	1150	1120	12
	2045	single/twin	760	1250	1220	12

**TM series**

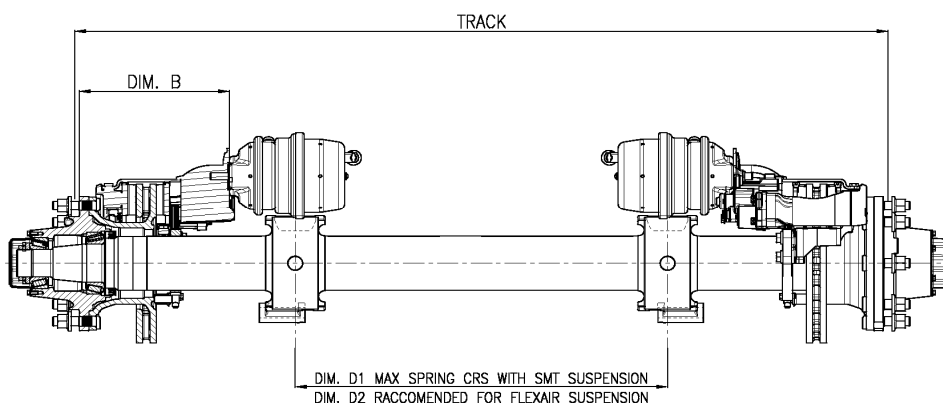

<b>378x45 (K) DISC BRAKE</b>						
<i>Type</i>	<i>Track</i>	<i>Wheel</i>	<i>B</i>	<i>D1 max</i>	<i>D2 max</i>	<i>Cap. t</i>
<i>TMK#225</i>	<i>1820</i>	<i>twin</i>	<i>336</i>	<i>920</i>	<i>890</i>	<i>10</i>
	<i>1850</i>	<i>twin</i>	<i>336</i>	<i>950</i>	<i>920</i>	<i>10</i>
	<i>1880</i>	<i>twin</i>	<i>336</i>	<i>980</i>	<i>950</i>	<i>10</i>
	<i>1920</i>	<i>twin</i>	<i>336</i>	<i>1020</i>	<i>990</i>	<i>10</i>
<i>2045</i>	<i>single</i>	<i>336</i>	<i>1145</i>	<i>1115</i>	<i>10</i>	
<i>TMK#250</i>	<i>1950</i>	<i>twin</i>	<i>336</i>	<i>1095</i>	<i>1065</i>	<i>12</i>