

# SUSPENSION CS

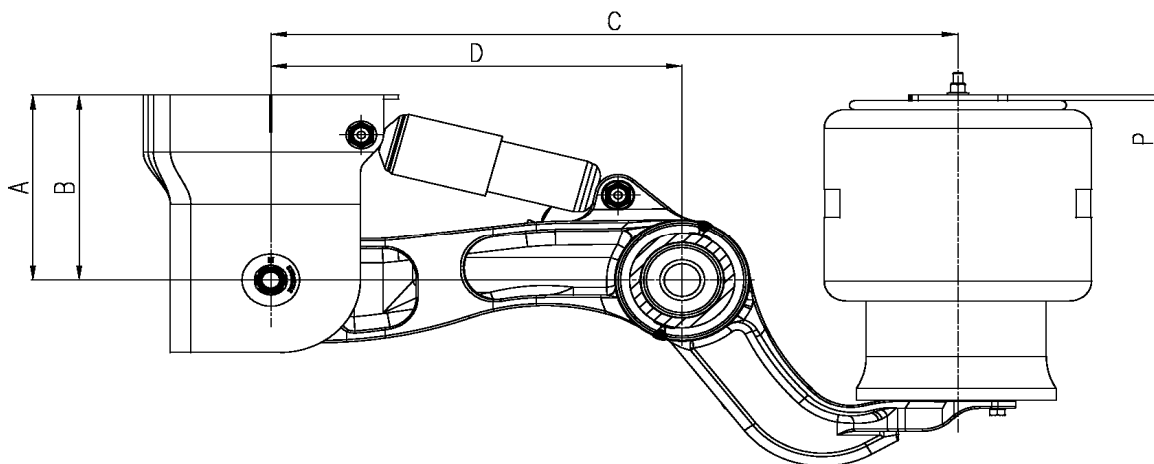

Type	Cap. t	A (R H)	B	C	D	P
CS9eL	9	225 - 275	250	835	500	0
	9	275 - 325	300	835	500	50
	9	325 - 375	350	835	500	100

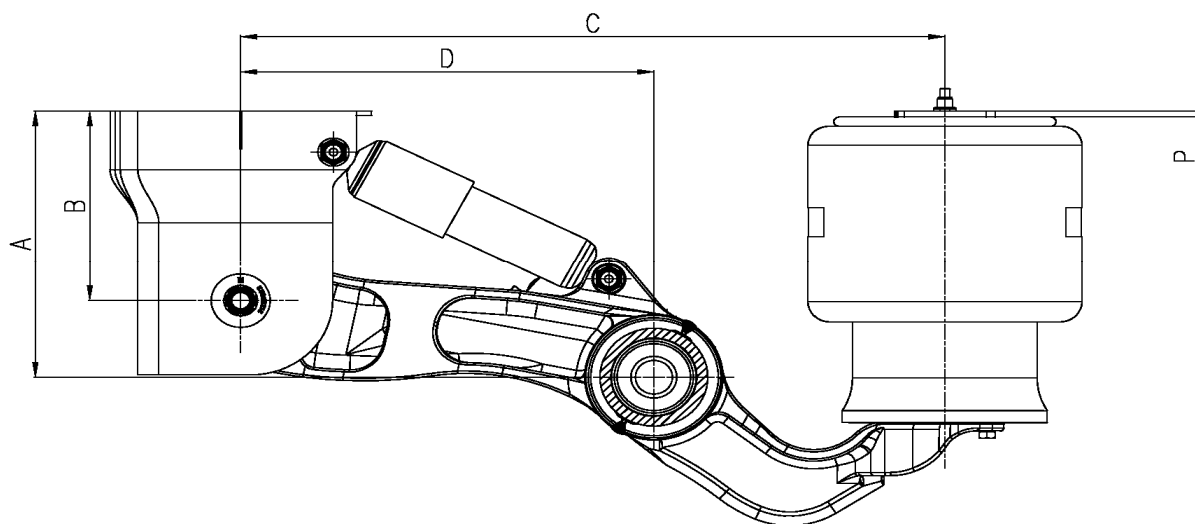

Type	Cap. t	A (R H)	B	C	D	P
CS9eT	9	325 - 375	250	835	490	0
	9	375 - 425	300	835	490	50
	9	425 - 475	350	835	490	100
	9	475 - 500	375	835	490	125

# SUSPENSION CS

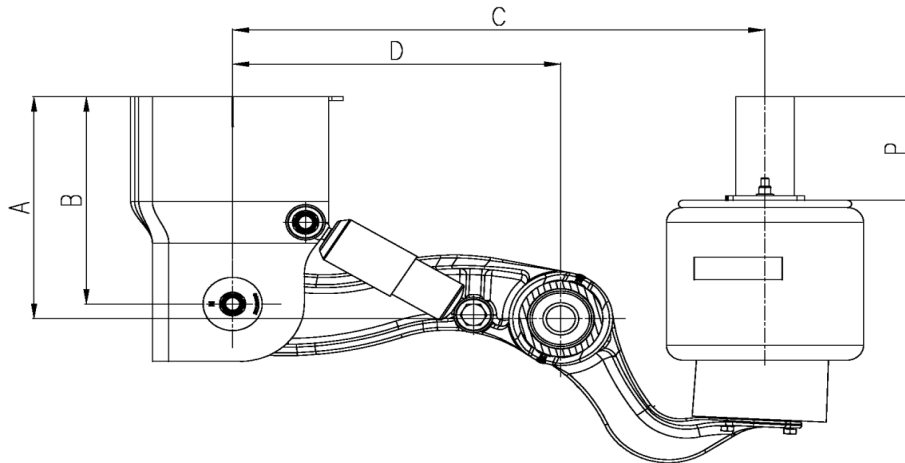

Type	Cap. t	A (R H)	B	C	D	P
<b>CS9iL</b>	9	200	175	810	499	8
	9	225	200	810	499	25
	9	250	225	810	499	50
	9	275	250	810	499	75
	9	300	275	810	499	100
	9	325	300	810	499	125
	9	350	325	810	499	150
	9	375	350	810	499	175

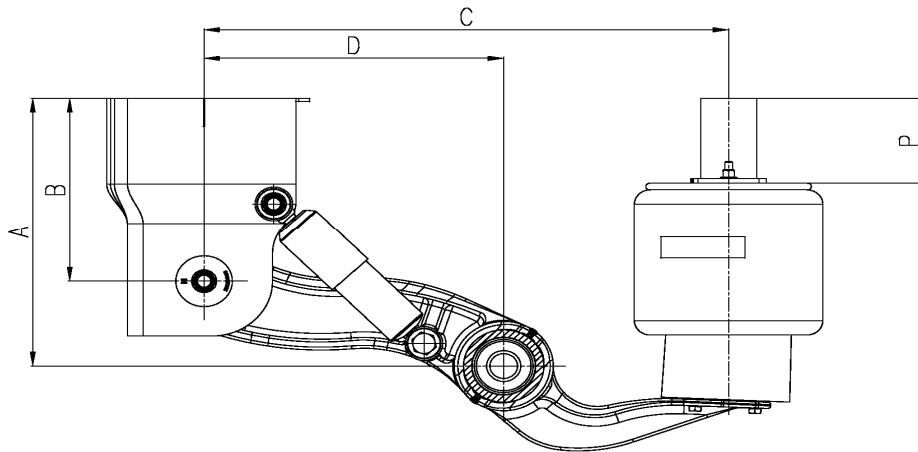

Type	Cap. t	A (R H)	B	C	D	P
<b>CS9iT</b>	9	325	175	835	477	8
	9	350	200	835	477	25
	9	375	225	835	477	50
	9	400	250	835	477	75
	9	425	275	835	477	100
	9	450	300	835	477	125
	9	475	325	835	477	150
	9	500	350	835	477	175

# SUSPENSION CS

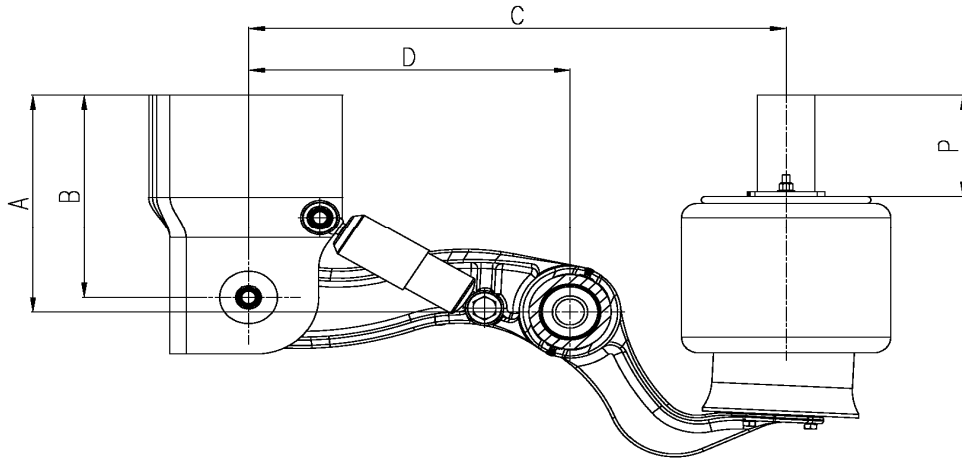

Type	Cap. t	A (R H)	B	C	D	P
<b>CS10iL</b>	10,5	200	175	835	499	8
	10,5	225	200	835	499	25
	10,5	250	225	835	499	50
	10,5	275	250	835	499	75
	10,5	300	275	835	499	100
	10,5	325	300	835	499	125
	10,5	350	325	835	499	150
	10,5	375	350	835	499	175

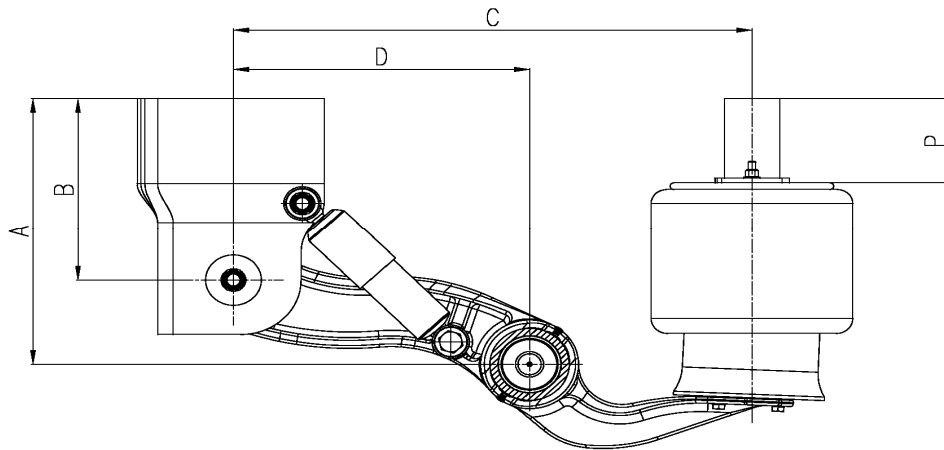

Type	Cap. t	A (R H)	B	C	D	P
<b>CS10iT</b>	10,5	325	175	835	499	8
	10,5	350	200	835	499	25
	10,5	375	225	835	499	50
	10,5	400	250	835	499	75
	10,5	425	275	835	499	100
	10,5	450	300	835	499	125
	10,5	475	325	835	499	150
	10,5	500	350	835	499	175